

SLINGSHOT

HOVER GLIDE
FWIND FOIL

QUICK START GUIDE

THE HOVER GLIDE MODULAR HYDROFOILS

ONE FOIL PLATFORM, FIVE SPORTS, ALL ABILITIES, STYLES, AND CONDITIONS.

Congratulations on the purchase of your new Hover Glide FWind Foil

Be sure to head over to [SlingshotSports.com](https://www.SlingshotSports.com) to register your new product and to sign up for Foil Academy (www.foil-academy.com). Foil Academy is a free video course for Foil users. Members of Foil Academy will discover all aspects of learning to foil safely, without fear or stress.

To take advantage of this modular system and expand your foiling experience you will find our ala carte wing selector here: <https://tinyurl.com/y42pcolp>

ATTENTION: When switching Hover Glide wings please note that some setups require different lengths of hardware. Please consult the **PRODUCT SUPPORT PAGE** <https://www.slingshotsports.com/slingshot-product-support> for the proper mounting and hardware information or contact info@slingshotsports.com

INFINITY WING 76cm NEOPRENE COVER
SKU: 120711066

STABILIZER 42cm NEOPRENE COVER
SKU: 120711069

HOVER GLIDE FWIND V3 CASE
SKU: 120711020

MOUNTING HARDWARE PACK

— (4) M8 x 25mm
COUNTERSUNK BOLTS

— (4) M8 TRACK NUTS
SKU 39020035

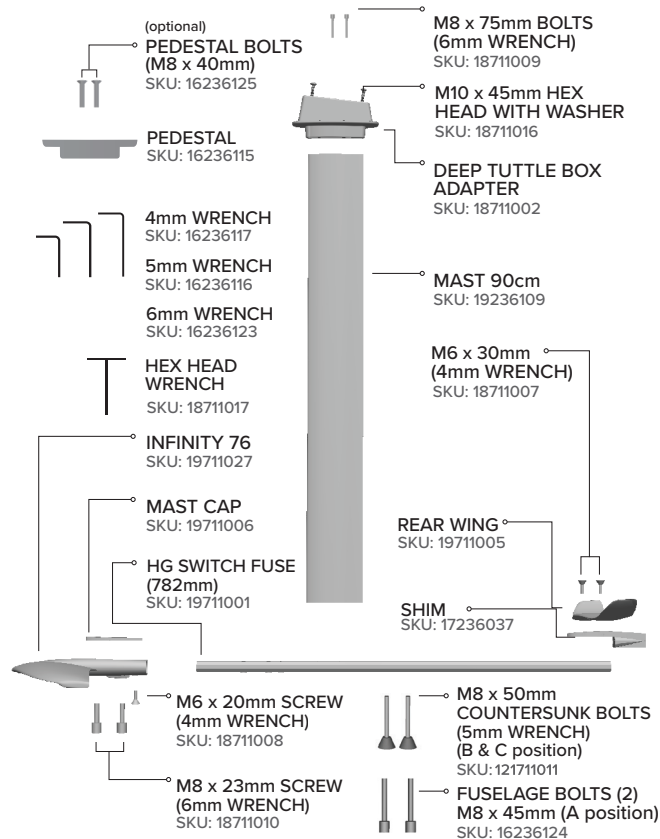

SWITCH FUSE

Switch Fuse: Rotate 180 degrees to change foil position.

Slingshot's Switch Fuse is an ingenious design that allows the foil to be configured in three different positions to accommodate for varying board setups, rider preferences and skill levels. Below are general guidelines for the Switch Fuse. You may need to try all positions to determine which works best for your board setup and skill level, and you may need to switch positions as you progress.

1. The Switch Fuse has three settings- mast forward "A" position, "B" position and mast back "C" position. The forward setting places the mast closer to the front wing, which brings the front wing closer to the rear of your board; the back settings places the mast closer to the center of the fuselage, which brings the front wing toward the center of your board.
2. As a general rule of thumb when determining which setting to start with, you want the front wing located as close to the center of your stance as possible.
3. Evaluate your board setup, footstrap position and stance location to determine which Switch Fuse setting you should start with. In general, if your footstraps are located at the far back of your board, start with the fuse in the mast forward "A" position. If your footstraps are more forward, start with the fuse on the "B" and "C" position setting to bring the front wing closer to the center of your stance.

General performance differences:

Forward position A: Moves the front wing toward the rear of your board. This has the effect of less lift and less need for heavy front foot pressure. For beginners, this can be helpful in getting the feel of the foil without having to focus as much on keeping the board level and preventing the foil from breaching. We recommend setting up foil in this position when starting.

Position B and C: Moves the front wing forward, which results in earlier lift. If your stance is set back, you'll need more front foot pressure to keep the board level and prevent the foil from breaching. This position is helpful for completing smooth transitions, when you need to shift your weight forward while remaining on foil.



MAST FORWARD: "A" POSITION



"B" POSITION



MAST BACK: "C" POSITION

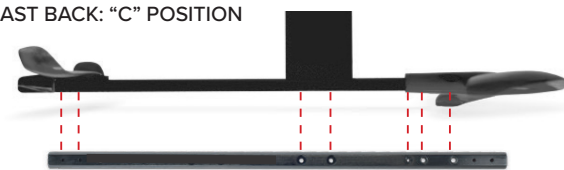

FOIL ASSEMBLY POSITION "A"

*Coat all bolt hardware with Lanolin oil or marine-grade grease and wrap with Teflon tape before assembling your foil. (see maintenance section for details)

1. Position fuselage so that the counter-sunk holes are facing DOWN.
2. Attach the pedestal to the mast with the two M8 X 40MM bolts, tightening each one bit by bit until both are tight.
3. Slide the front wing and fuselage together so that the three bolt holes in each line up.
4. Slide the mast onto its designated location on the wing, also ensuring all holes line up.
5. Bolt the front wing, mast and fuselage together. To do this, you may find it easier to flip the mast over and balance it on the pedestal. Start with the two M8 X 45 MM bolts, tightening each one bit by bit until both are tight. Finish with the M6 X 20MM counter sunk bolt to ensure a tight and secure connection.
6. Connect rear wing components to fuselage. First, nest the two rear wing components together making sure the bolt holes in each line up. Make sure that the rear wing is oriented correctly with the wings flaring upwards, opposite of the front wing. Next bolt the two rear wing components to the mast, tightening each one bit by bit until both are tight.

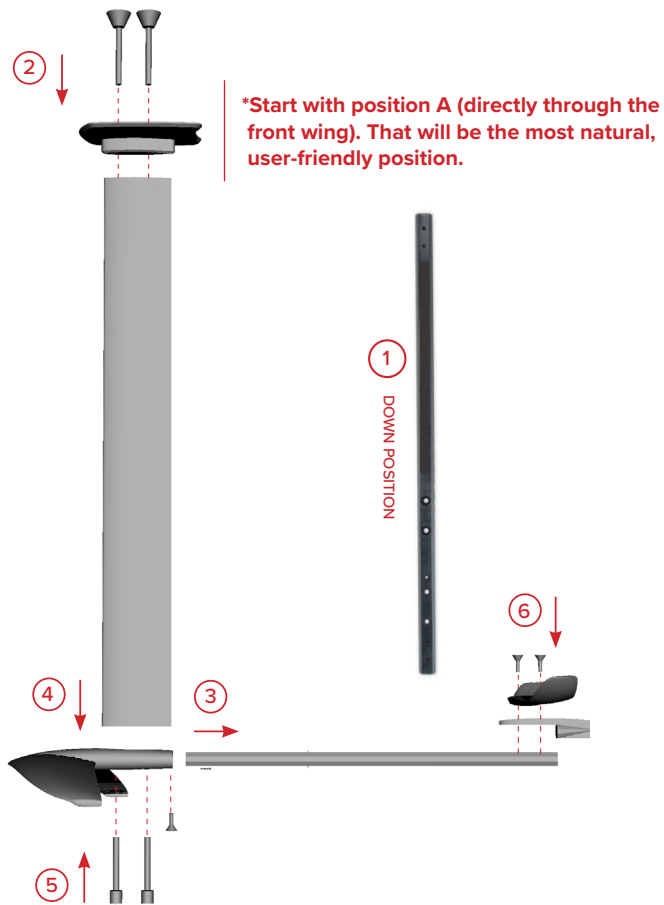

FOIL ASSEMBLY POSITION “B”

*Coat all bolt hardware with Lanolin oil or marine-grade grease and wrap with Teflon tape before assembling your foil. (see maintenance section for details)

1. Position fuselage so that the counter-sunk holes are facing DOWN.
2. Connect the fuselage to the front wing and mast cap. Insert the fuselage into the front wing. Align the three holes on the underside. Insert the one (1) M6 x 20mm set screw and tighten securely. Locate the front mast cap over the corresponding cutout in the top of the wing and tap cap into place. Tighten two (2) M8x23mm countersunk bolts in place.
3. Connect rear wing to fuselage. As pictured in the diagram, align the rear shim to the back of the fuselage, then stack the rear wing (winglets pointing up) on top of the shim. The surfaces of the parts will align naturally when done properly. Use the two (2) M6x30mm screws and tighten securely.
4. Attach the mast to the fuselage using the two (2) M8x50mm tapered bolts. Ensure the thinner edge of the mast is facing the back wing and the “Slingshot” branding reads top to bottom (the letter “t” will be closest to the fuselage).
5. Attach the Tuttle box and/or pedestal base adapter to the top of the mast using the appropriate hardware.

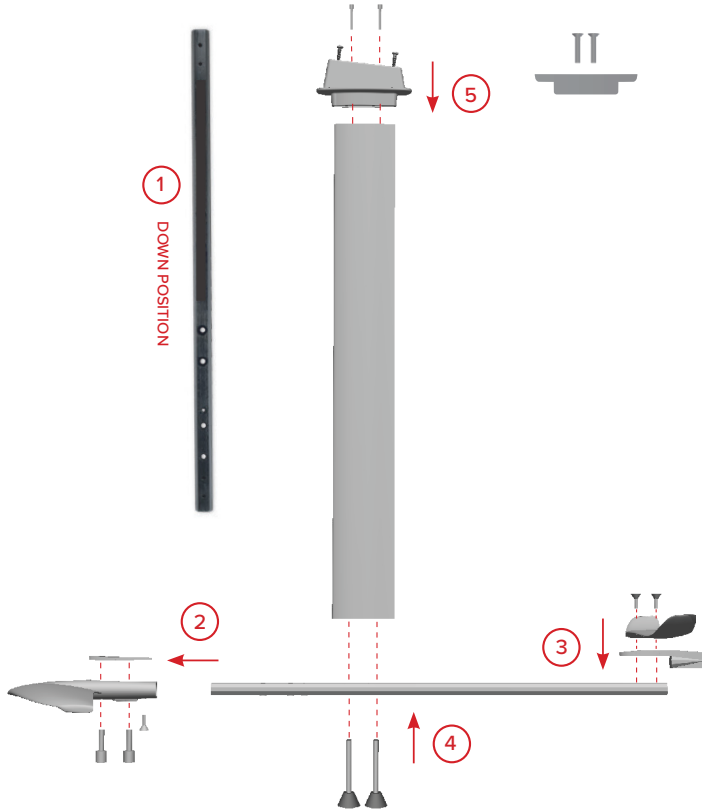

FOIL ASSEMBLY POSITION “C”

*Coat all bolt hardware with Lanolin oil or marine-grade grease and wrap with Teflon tape before assembling your foil. (see maintenance section for details)

1. Position fuselage so that the counter-sunk holes are facing **DOWN**. Next switch the direction of the fuse.
2. Connect the fuselage to the front wing and mast cap. Insert the fuselage into the front wing. Align the three holes on the underside. Insert the one (1) M6 x 20mm set screw and tighten securely. Locate the front mast cap over the corresponding cutout in the top of the wing and tap cap into place. Tighten two (2) M8x23mm countersunk bolts in place.
3. Connect rear wing to fuselage. As pictured in the diagram, align the rear shim to the back of the fuselage, then stack the rear wing (winglets pointing up) on top of the shim. The surfaces of the parts will align naturally when done properly. Use the two (2) M6x30mm screws and tighten securely.
4. Attach the mast to the fuselage using the two (2) M8x50mm tapered bolts. Ensure the thinner edge of the mast is facing the back wing and the “Slingshot” branding reads top to bottom (the letter “t” will be closest to the fuselage).
5. Attach the Tuttle box and or pedestal base adapter to the top of the mast using the appropriate hardware.

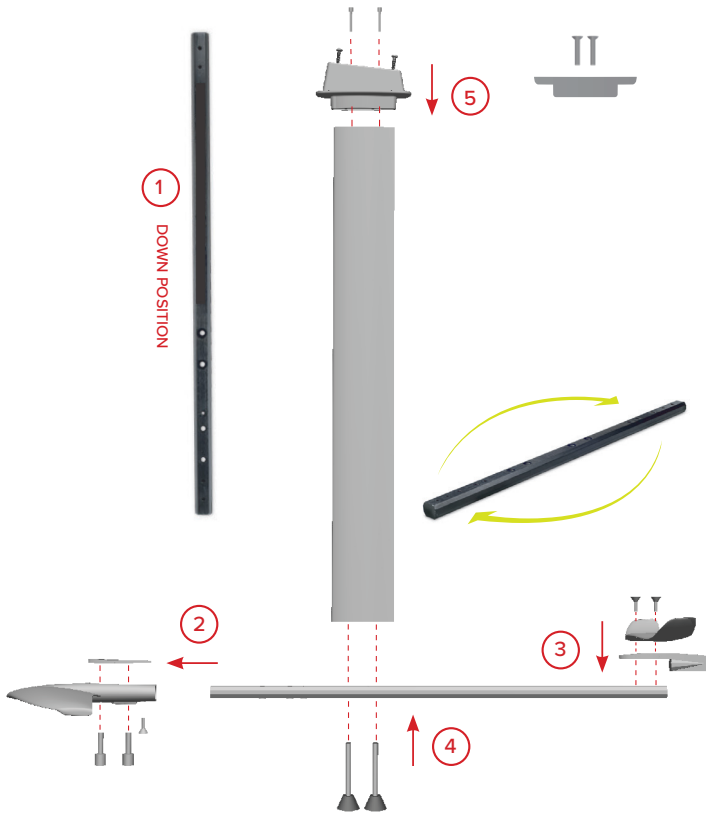

ATTACHING TUTTLE MOUNT TO BOARD

1. Double check the bolts that connect the mast to the tuttle box interface are firmly tightened.
2. Flip your board upside down and insert the foil.
3. Carefully flip your board on its side, insert the remaining two M10 bolts (M10 x 60mm) and tighten securely.

*Note: The mounting hardware size is M10. Your board may be set for narrower diameter hardware; if so you'll need to drill the hole to accommodate the M10 hardware.

ATTACHING FOIL TO BOARD

1. To attach your fully assembled foil to your board, place your board upside down and slide the four female pieces of your mounting hardware into slots in the tracks of your board, two on each side.

Note: Mounting hardware comes packaged with Slingshot foil boards, and is not included in the foil package.

2. Carefully place your foil over the mounting track so the front hole pattern in the pedestal line up with the mounting hardware. Be extra cautious with your foil in this position; components are fragile and can damage easily if it gets knocked down or blown over.
3. Bolt your foil to your board, tightening each bolt bit by bit until all four are equally tight.

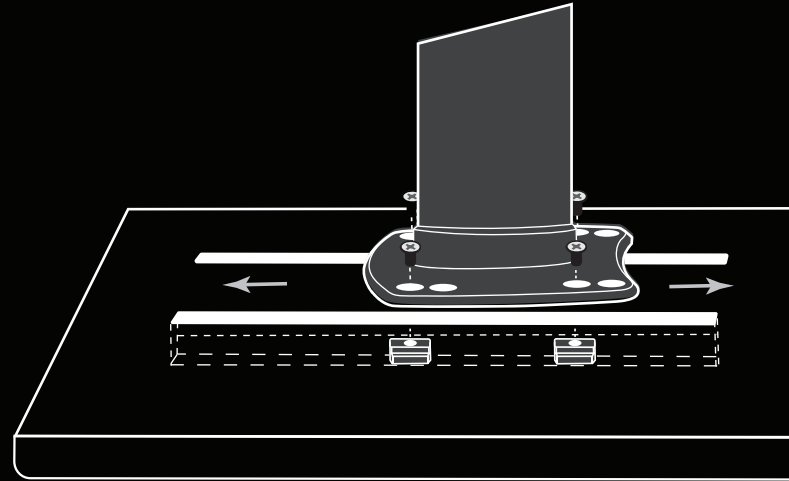

IMPORTANT NOTE: When getting started with the Hover Glide FWind, we recommend mounting the foil as far back on the board as possible until you get a feel for your new setup. This means using the front hole pattern on the pedestal and sliding the track as far back as possible. This is the most balanced position for this foil/board combination, particularly when riding with footstraps. We highly recommend this position until you gain the experience and confidence necessary to try other locations.

▲ WARNING

- ALWAYS FAMILIARIZE YOURSELF WITH ALL APPLICABLE FEDERAL, STATE, AND LOCAL LAWS, THE WATERWAYS AND AREA, AND THE PROPER USE OF THE EQUIPMENT.
- ALWAYS READ YOUR OWNER'S MANUAL.
- ALWAYS HAVE A PERSON OTHER THAN THE BOAT OPERATOR AS AN OBSERVER AND AGREE ON A SET OF HAND SIGNALS.
- ALWAYS INSPECT ALL EQUIPMENT INCLUDING THE TOW ROPE PRIOR TO EACH USE. NEVER USE ANY EQUIPMENT WITH MISSING, DAMAGED, OR DEFECTIVE PARTS.
- ALWAYS WEAR A U.S. COAST GUARD APPROVED TYPE III FLotation VEST (PFD).
- ALWAYS RIDE IN CONTROL AND AT SPEEDS APPROPRIATE FOR YOUR ABILITY.
- ATTEMPTING LAND OR DOCK STARTS, OR USING MAN-MADE OBSTACLES SUCH AS RAILS, SLIDERS, AND JUMPS, INCREASES THE RISK OF INJURY OR DEATH. USE THIS PRODUCT ONLY IN WATER.
- NEVER RIDE IN SHALLOW WATER OR NEAR SHORE, PILING, DOCKS, RAFTS, SWIMMERS, OTHER WATERCRAFT, OR OTHER OBSTACLES.
- ALWAYS USE AN APPROPRIATE SIZE BOARD AND BINDING. BE AWARE THAT BINDINGS WILL NOT RELEASE FROM THE BOARD, AND THAT YOUR FEE MAY OR MAY NOT COME OUT OF THE BINDINGS IN A FALL.
- FALLING AND THE INJURIES THAT MAY RESULT ARE INHERENT RISKS IN THE SPORT.
- DO NOT OPERATE ANY WATERCRAFT OR RIDE UNDER THE INFLUENCE OF ALCOHOL OR DRUGS.

THE WARNINGS AND PRACTICES SET FORTH ABOVE REPRESENT SOME COMMON RISKS ENCOUNTERED BY USERS. THIS LIST DOES NOT PURPORT TO COVER ALL INSTANCES OF RISK OR DANGER. PLEASE USE COMMON SENSE AND GOOD JUDGMENT.

MADE IN CHINA

SAFETY

Foiling comes with a unique set of challenges, risks and danger above and beyond those inherent to the sport of wakeboarding. Know your limits, know your gear, know the conditions and use extra caution to keep yourselves and others safe in the water. Here are a few basic safety precautions we recommend taking.

1. The use of a helmet and wetsuit are highly recommended, especially when learning, to help protect yourself from impacts with your board and foil.
2. Check all foil screws and components before every session to ensure all connections are tight and components are in proper working order.
3. Use extreme caution when foiling near other people or objects. Give yourself and others a wide berth.
4. Do not foil in shallow water.
5. Pay extra attention to wind and water conditions; always air on the side of caution.
6. Be aware that your foil will carry speed and drift on its own faster and farther than a regular board.
7. **MANDATORY FOR ALL RIDERS:** Learn on the (46cm) 18" mast before moving on to the (61cm) 24" mast.

MAINTENANCE

It is imperative to clean and lubricate your foil regularly, especially after use in salt water. This is true for all of your gear, but especially for your foil. Following these simple steps on a regular basis will minimize corrosion and prevent the components of your foil from fusing together.

1. Coat all bolt hardware with Lanolin oil or marine-grade grease and wrap with Teflon tape before assembling your foil.
2. Rinse your foil well after EVERY exposure to salt water.
3. Regularly disassemble, clean and inspect all components.
4. Regularly lubricate foil components and hardware at all connection points. Use a general marine-grade grease or Lanolin oil. Lubricate where components come together to help prevent wear and corrosion.
5. Ensure all hardware is screwed firmly in place before each use.
6. Be careful when handling your foil and use your protective foil bag whenever possible.



LUBRICATE HARDWARE:

In a clean, sand-free area, carefully coat all bolt hardware, bolt holes and ALL connection points with a layer of Lanolin oil or marine-grade grease. Coat anywhere that parts touch each other to prevent them from corroding and fusing together. Don't forget the inside of your front wing. A cotton swab works well for this. Lanolin, or wool's wax, is a natural oil that acts as a lubricant and water repellent. If you have an allergy to wool, be sure to take precautions or use a different oil.



WRAP HARDWARE WITH TEFLON TAPE:

Wrap all bolt hardware in a thin layer of Teflon Tape. This will be a little tricky with the bolts covered in a layer of Lanolin oil/ or marine-grade grease, but it acts as a second layer of protection to prevent your bolts from corroding and fusing with other components of your foil. Wrap the tape tight so it feeds through the threads of the foil properly without peeling off.

SLINGSHOT SUPPORT

FOR FURTHER INSTRUCTIONS GO TO:
WWW.SLINGSHOTSPORTS.COM

CONTACT US:
INFO@SLINGSHOTSPORTS.COM

RIDER SERVICE LINE IN THE US:
[877.775.4832](tel:8777754832)

INTERNATIONAL PHONE
[509.427.4950](tel:5094274950)

LOG ON TO:

SLINGSHOTSPORTS.COM/REGISTRATION

TO REGISTER YOUR PRODUCT. RECEIVE SERVICE
GUARANTEES, AND ACCESS TO YOUR OWN
PERSONAL RIDER HOTLINE PROFESSIONAL.

