

PHANTASM
899 / 710 LOWER PACKAGE

SLINGSHOT

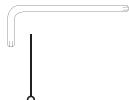

T30 TORX WRENCH
*SKU: 121237008

PTM 899 FRONT WING
NEOPRENE COVER
SKU: 122825023

PHANTASM 360 STABILIZER
NEOPRENE COVER
SKU: 122826003

PHANTASM MEDIUM
CARRYING CASE
SKU: 122824001

*COMPLETE HARDWARE
PACKAGE
SKU: 122827017



710 FUSELAGE
SKU: 121290710

PTM 899
FRONT WING
SKU: 1240490899

PS 360
STABILIZER
SKU: 1240490360

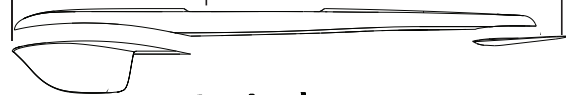

M6 X 25mm
FLATHEAD
*SKU: 122827010

M6 X 30mm
FLATHEAD
*SKU: 122827010

M6 X 25mm
FLATHEAD
SCREW
*SKU: 122827010

M6 X 25mm
SOCKET HEAD
SCREWS
*SKU: 122827010

M6 X 18mm
FLATHEAD
SCREWS
*SKU: 122827010

FOIL ASSEMBLY

1. Coat all bolt hardware with Lanolin oil or a marine-grade grease and wrap with Teflon tape before assembling your foil. (see maintenance section for details)
2. Connect the front wing to the fuselage using the M6x25mm flathead screw for the forward hole, the M6x30mm screw for the center hole and the M6x25mm screw for the third hole.
3. Connect the rear wing to the fuselage using the two M6 x 18mm flathead screws.
4. Position the mast so that it is vertical. Be careful of knocking the mast over, attaching the pedestal to an upside down board can help with stability.
5. Insert the mast foot into the fuselage slot so that the 3 holes align and fasten with the three M6x25mm socket head screws. It may be necessary to use a rubber mallet to fit the fuselage on and off the mast for the first few sessions.

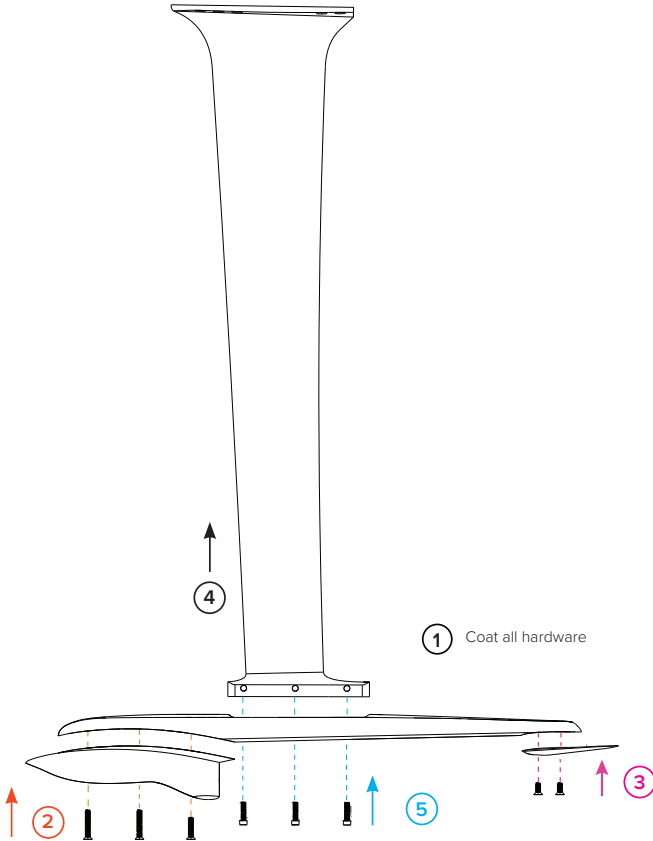

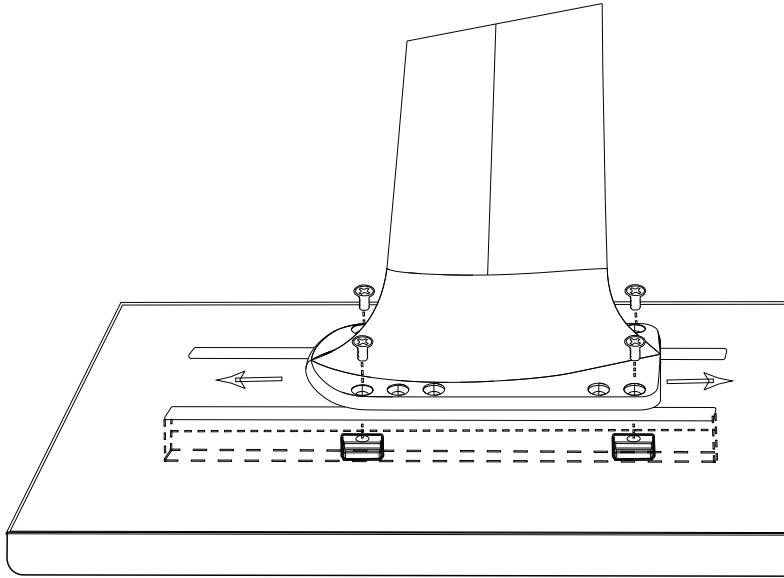

ATTACHING FOIL TO BOARD

1. To attach your fully assembled foil to your board, place your board upside down and slide the four female pieces of your mounting hardware into slots in the tracks of your board, two on each side.

Note: Mounting hardware comes packaged with Slingshot foil boards, and is not included in the foil package.

2. Carefully place your foil over the mounting track so the front hole pattern in the pedestal line up with the mounting hardware. Be extra cautious with your foil in this position; components are fragile and can damage easily if it gets knocked down or blown over.
3. Bolt your foil to your board, tightening each bolt bit by bit until all four are equally tight.

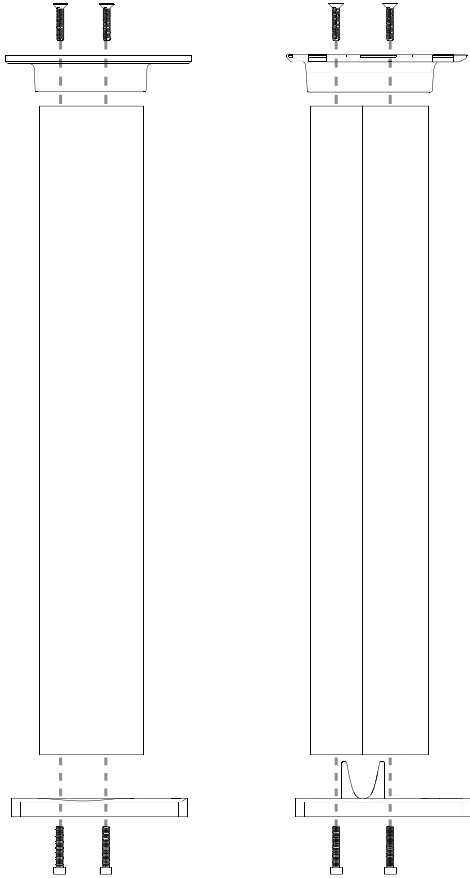

PHANTASM ALUMINUM MAST ASSEMBLY INSTRUCTIONS

1. Coat all screws with with lanolin oil or marine-grade grease and wrap with Teflon tape before assembling mast.
2. Connect the pedestal to the top of the mast with the two M8 x 40mm flathead screws.
3. Connect the fuselage adapter foot to the other end of the mast with the two M8 x 45mm socket head screws.

SAFETY

Foiling comes with a unique set of challenges, risks and dangers. Know your limits, know your gear, know the conditions and use extra caution to keep yourselves and others safe in the water. Here are a few basic safety precautions we recommend taking.

1. The use of a helmet, wetsuit, neoprene booties, and impact vest are highly recommended, especially when learning, to help protect yourself from impacts with your board and foil.
2. Check all foil screws and components before every session to ensure all connections are tight, and components are in proper working order.
3. Use extreme caution when foiling near other people or objects. Give yourself and others a wide berth.
4. Do not foil in shallow water.
5. Pay extra attention to wind and water conditions; always air on the side of caution.
6. Be aware that your foil will carry speed and drift on its own faster and farther than a regular board.

MAINTENANCE

It is imperative to clean and lubricate your foil regularly, especially after use in salt water. This is true for all of your gear, but especially for your foil. Following these simple steps on a regular basis will minimize corrosion and prevent the components of your foil from fusing together.

1. Coat all bolt hardware with Lanolin oil or a marine-grade grease and wrap with Teflon tape before assembling your foil.
2. Rinse your foil well after EVERY exposure to salt water.
3. Regularly disassemble, clean and inspect all components.
4. Regularly lubricate foil components and hardware at all connection points. Use a general marine-grade grease or Lanolin oil. Lubricate where components come together to help prevent wear and corrosion.
5. Ensure all hardware is screwed firmly in place before each use.
6. Be careful when handling your foil and use your protective neoprene covers whenever possible.



LUBRICATE HARDWARE:

In a clean, sand-free area, carefully coat all bolt hardware, bolt holes and ALL connection points with a layer of Lanolin oil or marine-grade grease. Coat anywhere that parts touch each other to prevent them from corroding and fusing together. Don't forget the inside of your fuselage to mast slot. A cotton swab works well for this. Lanolin, or wool's wax, is a natural oil that acts as a lubricant and water repellent. If you have an allergy to wool, be sure to take precautions or use a different oil.



WRAP WITH TEFLON TAPE:

Wrap all bolt hardware in a thin layer of Teflon Tape. This will be a little tricky with the bolts covered in a layer of Lanolin oil/ or marine-grade grease, but it acts as a second layer of protection to prevent your bolts from corroding and fusing with other components of your foil. Wrap the tape tight so it feeds through the threads of the foil properly without peeling off.

SLINGSHOT

CONTACT:

INFO@SLINGSHOTSPORTS.COM

RIDER SERVICE IN THE US:

877.775.4832

INTERNATIONAL PHONE:

509.427.4950

SHIPPING ADDRESS:

390 EVERGREEN DRIVE, SUITE NORTH F
NORTH BONNEVILLE, WA USA 98639

WWW.SLINGSHOTSPORTS.COM