

**PHANTASM**  
**633 / 710 LOWER PACKAGE**

**SLINGSHOT**

## PHANTASM 633/710 PACKAGE

The Phantasm Freeride Infinity (PFI) 633/710 Lower Package features a larger, lower aspect front wing that gives it tons of lift, stability and dynamic performance at lower speeds, as well as a PS 400 carbon rear stabilizer and 710 fuse. The PFI 633 package was built to provide you with maximum freeride performance as the most predictable and user-friendly foil on the market.

At higher speeds, the PFI 633 will track and retain its stability, which aids in setting up for jibes and tacks and also prevents over-foiling. The larger surface area of the PFI 633 Front Wing, combined with the efficiency of carbon means it has a huge wind and speed range. The wing's unique inverted gull shape provides a crazy level of dynamic carving control and a self-centering flight you have to feel to believe.



COMPLETE FOIL SETUP

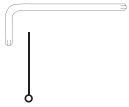

T30 TORX WRENCH  
\*SKU: 121237008

PFI 633 FRONT WING  
NEOPRENE COVER  
SKU: 122825000

PHANTASM 400 STABILIZER  
NEOPRENE COVER  
SKU: 122826000

PHANTASM SMALL  
CARRYING CASE  
SKU: 122824000

\*COMPLETE HARDWARE  
PACKAGE  
SKU: 122827000

710 FUSELAGE  
SKU: 121290710

PFI 633  
FRONT WING  
SKU: 121237003

PS 400  
STABILIZER  
SKU: 121237004

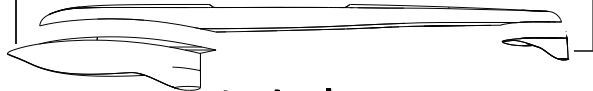

M6 X 37mm  
FLATHEAD  
\*SKU: 122827000

M6 X 40mm  
FLATHEAD  
\*SKU: 122827000

M6 X 30mm  
FLATHEAD  
SCREW  
\*SKU: 122827000

M6 X 25mm  
SOCKET HEAD  
SCREWS  
\*SKU: 122827000

M6 X 18mm  
FLATHEAD  
SCREWS  
\*SKU: 122827000



## FOIL ASSEMBLY

1. Coat all bolt hardware with Lanolin oil or a marine-grade grease and wrap with Teflon tape before assembling your foil. (see maintenance section for details)
2. Connect the front wing to the fuselage using the M6x37mm flathead screw for the forward hole, the M6x40mm screw for the center hole and the M6x30mm screw for the third hole.
3. Connect the rear wing to the fuselage using the two M6 x 18mm flathead screws.
4. Position the mast so that it is vertical. Be careful of knocking the mast over, attaching the pedestal to an upside down board can help with stability.
5. Insert the mast foot into the fuselage slot so that the 3 holes align and fasten with the three M6x25mm socket head screws. It may be necessary to use a rubber mallet to fit the fuselage on and off the mast for the first few sessions.

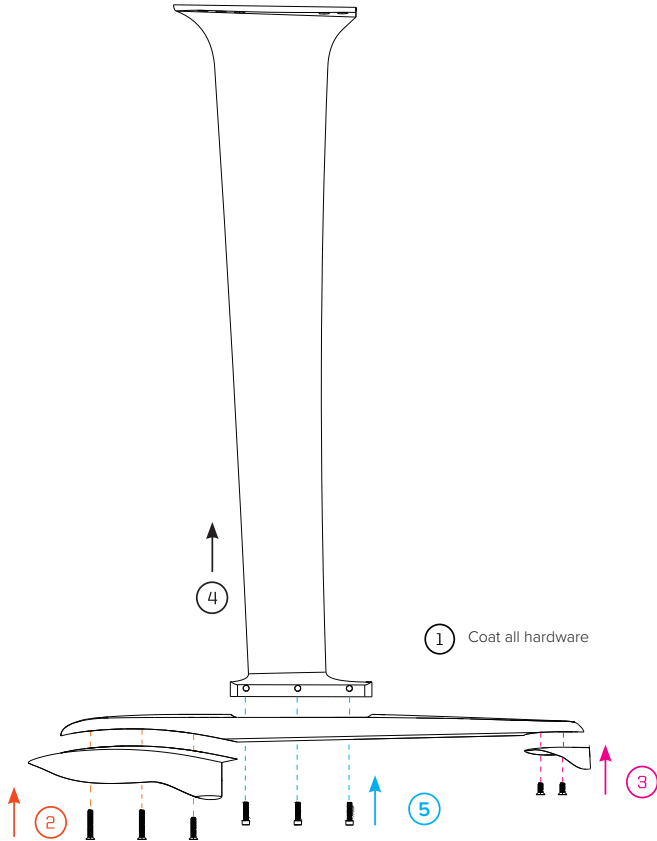

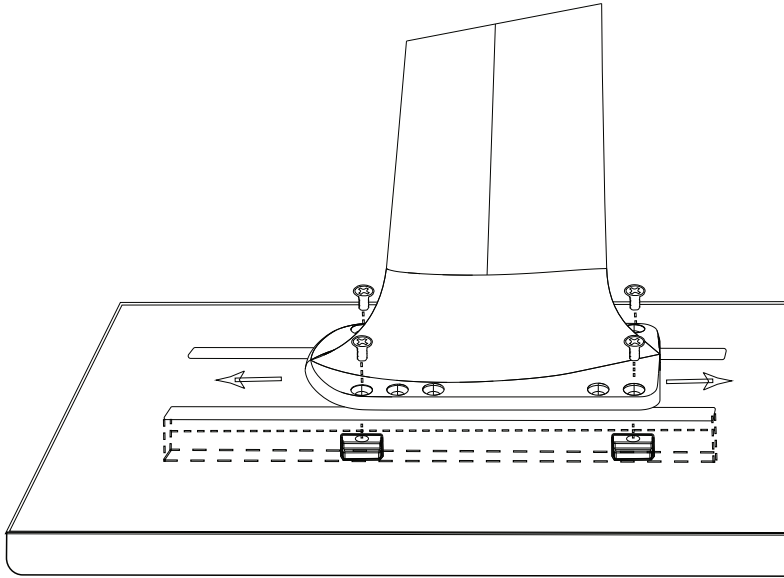

## ATTACHING FOIL TO BOARD

1. To attach your fully assembled foil to your board, place your board upside down and slide the four female pieces of your mounting hardware into slots in the tracks of your board, two on each side.

Note: Mounting hardware comes packaged with Slingshot foil boards, and is not included in the foil package.

2. Carefully place your foil over the mounting track so the front hole pattern in the pedestal line up with the mounting hardware. Be extra cautious with your foil in this position; components are fragile and can damage easily if it gets knocked down or blown over.
3. Bolt your foil to your board, tightening each bolt bit by bit until all four are equally tight.

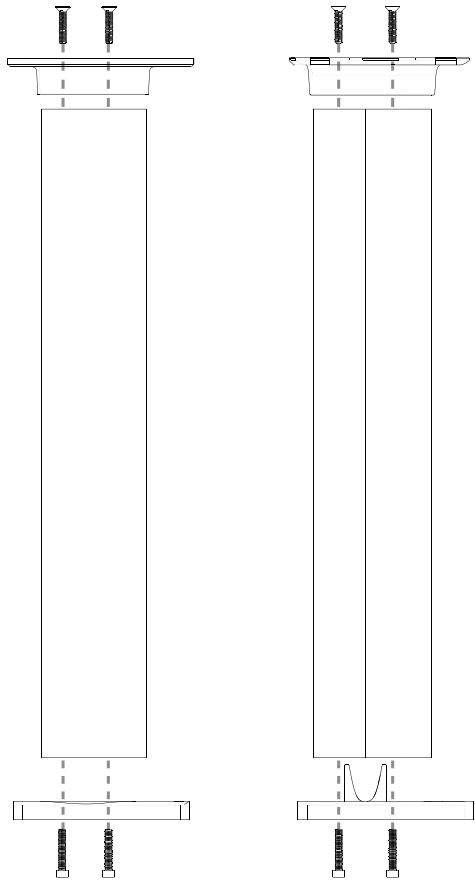

## PHANTASM ALUMINUM MAST ASSEMBLY INSTRUCTIONS

1. Coat all screws with lanolin oil or marine-grade grease and wrap with Teflon tape before assembling mast.
2. Connect the pedestal to the top of the mast with the two M8 x 40mm flathead screws.
3. Connect the fuselage adapter foot to the other end of the mast with the two M8 x 45mm socket head screws.

## **SAFETY**

Foiling comes with a unique set of challenges, risks and dangers. Know your limits, know your gear, know the conditions and use extra caution to keep yourselves and others safe in the water. Here are a few basic safety precautions we recommend taking.

1. The use of a helmet, wetsuit, neoprene booties, and impact vest are highly recommended, especially when learning, to help protect yourself from impacts with your board and foil.
2. Check all foil screws and components before every session to ensure all connections are tight, and components are in proper working order.
3. Use extreme caution when foiling near other people or objects. Give yourself and others a wide berth.
4. Do not foil in shallow water.
5. Pay extra attention to wind and water conditions; always err on the side of caution.
6. Be aware that your foil will carry speed and drift on its own faster and farther than a regular board.

## **MAINTENANCE**

It is imperative to clean and lubricate your foil regularly, especially after use in salt water. This is true for all of your gear, but especially for your foil. Following these simple steps on a regular basis will minimize corrosion and prevent the components of your foil from fusing together.

1. Coat all bolt hardware with Lanolin oil or a marine-grade grease and wrap with Teflon tape before assembling your foil.
2. Rinse your foil well after EVERY exposure to salt water.
3. Regularly disassemble, clean and inspect all components.
4. Regularly lubricate foil components and hardware at all connection points. Use a general marine-grade grease or Lanolin oil. Lubricate where components come together to help prevent wear and corrosion.
5. Ensure all hardware is screwed firmly in place before each use.
6. Be careful when handling your foil and use your protective neoprene covers whenever possible.



### **LUBRICATE HARDWARE:**

In a clean, sand-free area, carefully coat all bolt hardware, bolt holes and ALL connection points with a layer of Lanolin oil or marine-grade grease. Coat anywhere that parts touch each other to prevent them from corroding and fusing together. Don't forget the inside of your fuselage to mast slot. A cotton swab works well for this. Lanolin, or wool's wax, is a natural oil that acts as a lubricant and water repellent. If you have an allergy to wool, be sure to take precautions or use a different oil.

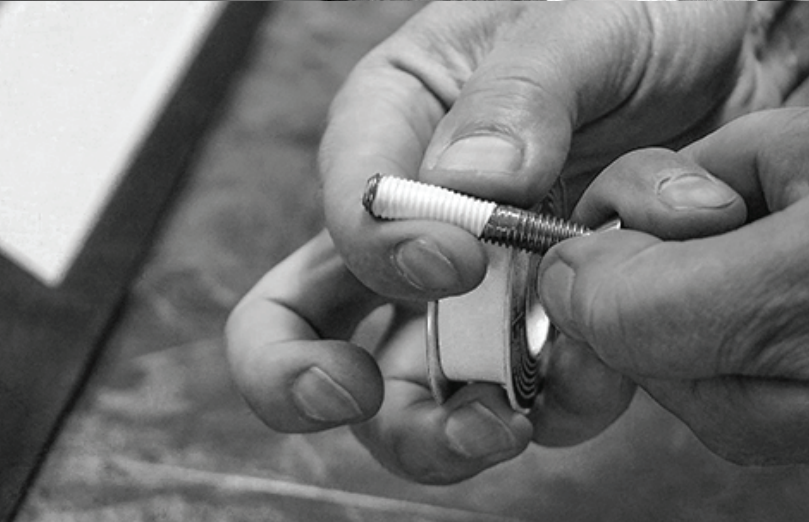

### **WRAP WITH TEFLON TAPE:**

Wrap all bolt hardware in a thin layer of Teflon Tape. This will be a little tricky with the bolts covered in a layer of Lanolin oil/ or marine-grade grease, but it acts as a second layer of protection to prevent your bolts from corroding and fusing with other components of your foil. Wrap the tape tight so it feeds through the threads of the foil properly without peeling off.



# SLINGSHOT

**CONTACT:**

INFO@SLINGSHOTSPORTS.COM

**RIDER SERVICE IN THE US:**

877.775.4832

**INTERNATIONAL PHONE:**

509.427.4950

**SHIPPING ADDRESS:**

390 EVERGREEN DRIVE, SUITE NORTH F  
NORTH BONNEVILLE, WA USA 98639

**WWW.SLINGSHOTSPORTS.COM**